

SECTION A-A

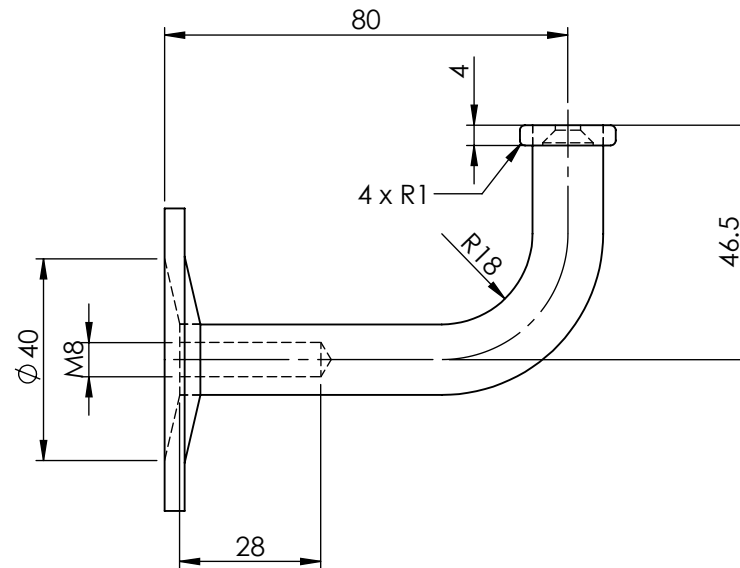

ITEM NO.	PART NUMBER	DESCRIPTION	QTY.	DRAWN	B DOOLAN	3/11/2016	CAT NO:	REV: B
				CHK'D	G SIMPSON	3/11/2016		
1	SS443FT	BRACKET	1	MATERIAL	304 STAINLESS STEEL		SS443FT	
2	LAG SCREW-M8-80	LAG SCREW-M8X80MM	1	FINISH	BRUSHED / POLISHED			
3	SCS-5-40	SCREW-C/SUNK-5MMX40MM	2	WEIGHT				
				 www.emro.com.au			DESCRIPTION:	
				<small>This drawing has been made with due care and attention however Emro do not accept any responsibility for variations. This drawing and information contained is the property of Emro and cannot be used without their consent.</small>			EXTENDED CONCEALED STAIR RAIL BRACKET-COMPLIES WITH AUSTRALIAN STANDARD AS1428.1-2009	