

SECTION A-A

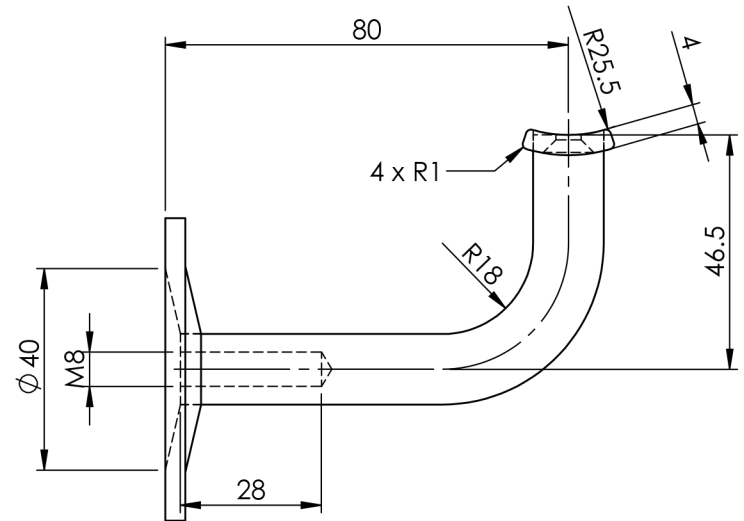

ITEM NO.	PART NUMBER	DESCRIPTION	QTY.	DRAWN	B DOOLAN	26/07/2016	CAT NO:	SS443CT	REV: A
				CHK'D	G SIMPSON	26/07/2016			
1	SS443CT	BRACKET	1	MATERIAL	304 STAINLESS STEEL		DESCRIPTION: EXTENDED CONCEALED STAIR RAIL BRACKET-COMPLIES WITH AUSTRALIAN STANDARD AS1428.1-2009		
2	LAG SCREW-M8-80	LAG SCREW-M8X80MM	1	FINISH	BRUSHED POLISHED				
3	SCS-5-40	SCREW-C/SUNK-5MMX40MM	2	WEIGHT					

www.emro.com.au
This drawing has been made with due care and attention, however Emro do not accept any responsibility for variations. This drawing and information contained is the property of Emro and cannot be used without their consent.