

DETAIL ITEM ④

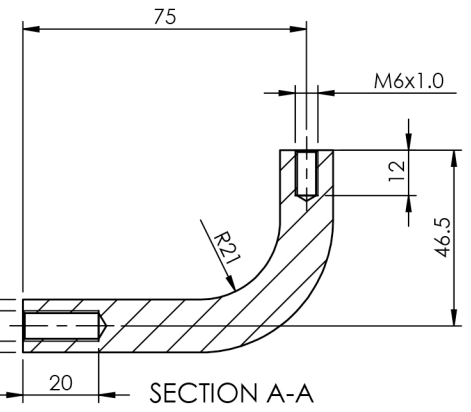
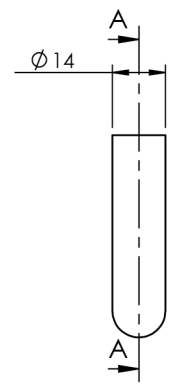
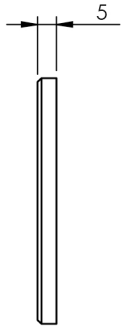

DETAIL ITEM ③

ITEM NO.	PART NUMBER	DESCRIPTION	QTY.	DRAWN	B DOOLAN	26/05/2017	CAT NO:	REV: A
1	SCS-5-40	SCREW-C/SUNK-5MMX40MM	2	CHK'D	G SIMPSON	26/05/2017	SS681CT-FTG304S DESCRIPTION: STAIR RAIL BRACKET-COMPLIES WITH CURRENT AS1428.1	
2	B-CS-M6-12	BOLT-C/SUNK-M6X12MM	1	MATERIAL	304 STAINLESS STEEL			
3	SS681-1	BRACKET	1	FINISH	SATIN			
4	SS681-2	WASHER	1	WEIGHT				
5	SS681-3	RAIL MOUNT	1					
6	SS681-4	ADAPTOR	1					
7	LAG SCREW-M8-80	LAG SCREW-M8X80MM	1					