

**halliday
baillie**

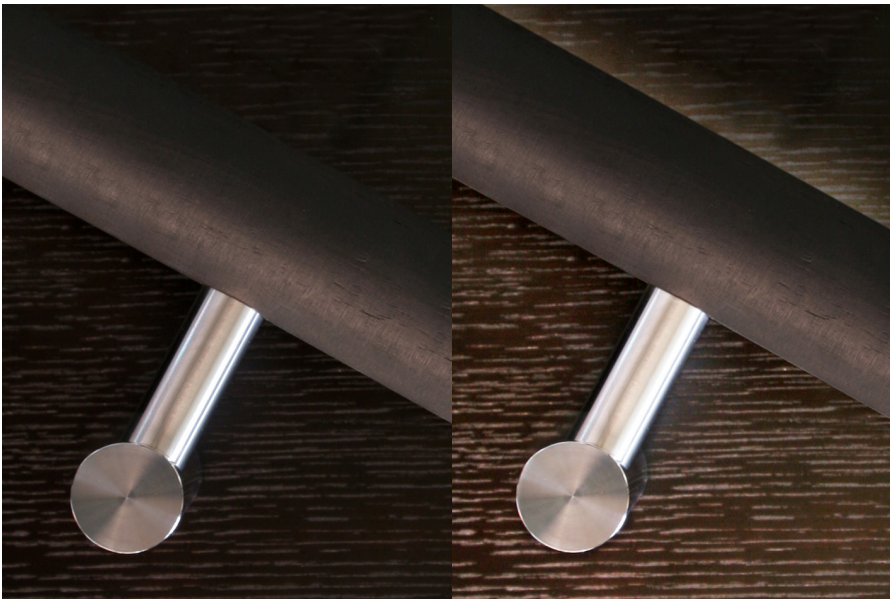

HB 528

HB 526

HB 526 STAINLESS STEEL STAIR RAIL BRACKETS WITH WIRING CAPABILITY

The Halliday + Baillie HB 526 has been developed from the HB 530 Bracket and incorporates a channel in both the body and upstand allowing for wiring to connect through the bracket to LED lighting strips.

The HB 525 - HB 528 brackets come in both wiring capable and 'blank' versions and are still suitable for use with 1.18" to 1.96" diameter rails.

Projection from wall (offstand) : 3.93"
Overall height (upstand) : 2.95"

Includes all fasteners. Epoxy required for installation, not included (please contact your local H+B dealer for further information).

Material : milled 316 marine grade Stainless Steel
Recommended Spacing : 23-32"

Available in 316 SS only. See finishes sheet for further details.

Glass fixing kits not available for styles HB 525, HB 526, HB 527 and HB 528.

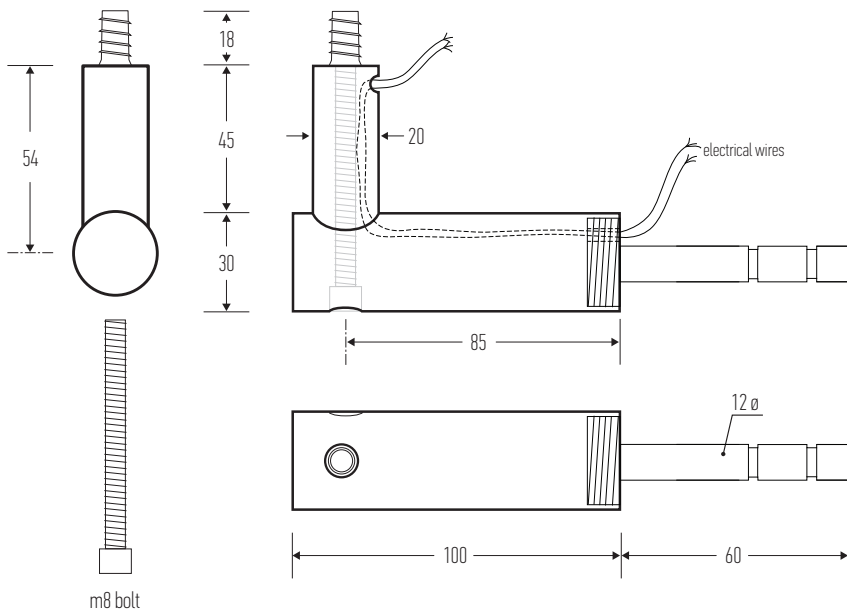

Halliday + Baillie brackets are tested in accordance with both the AS/NZS 1170.1:2002 (Structural Design Actions) standards and the International Building Code, IBC (2003) to comply with the 200lb fall rating.

Designed and manufactured in New Zealand. For more information on this product and others please visit www.hallidaybaillie.com. For dealers in North America, contact Bridgeport Worldwide +1-800-362-1484 www.BridgeportWorldwide.com/hallidaybaillie. All information subject to change.

