



ESV 100

ELECTRIC STRIKE

WEATHER RESISTANT

FEATURES:

- Stainless steel face plate & keeper
- Weather resistant
- Compatible with latch depth up to 15mm
- 2 or 24VDC Operation
- Easily change from Power to Lock / Power to Open
- Non-Monitored and Monitored versions available

SPECIFICATIONS:

Model:	ESV100 / ESV100M
Application:	Morticed Strike Power to Lock / Power to Open Field Interchangeable Non-handed Fully Reversible 12/24V
Voltage:	Dual Voltage 12VDC = 250mA / 24VDC = 150mA
Monitoring:	ESV100 - Non-monitored ESV100M - Monitored
Holding Strength:	680kg
Size:	124mm L x 32mm W x 30mm D
Approvals:	Cycle Tested Over 1,000,000, CE tick, ROHS Compliant

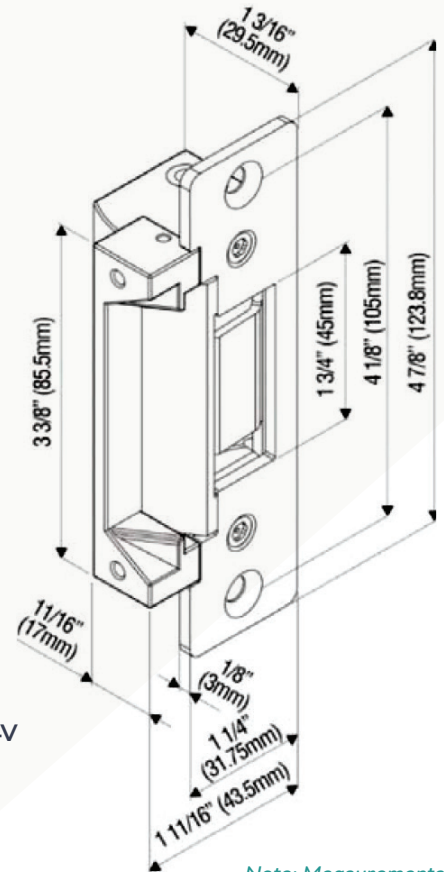

Note: Measurements are in mm

ACCESSORIES:



ESVEL25-100
Extension Lip 25mm



ESVEL50-100
Extension Lip 50mm

